

STEP/STAR

Goldhofer

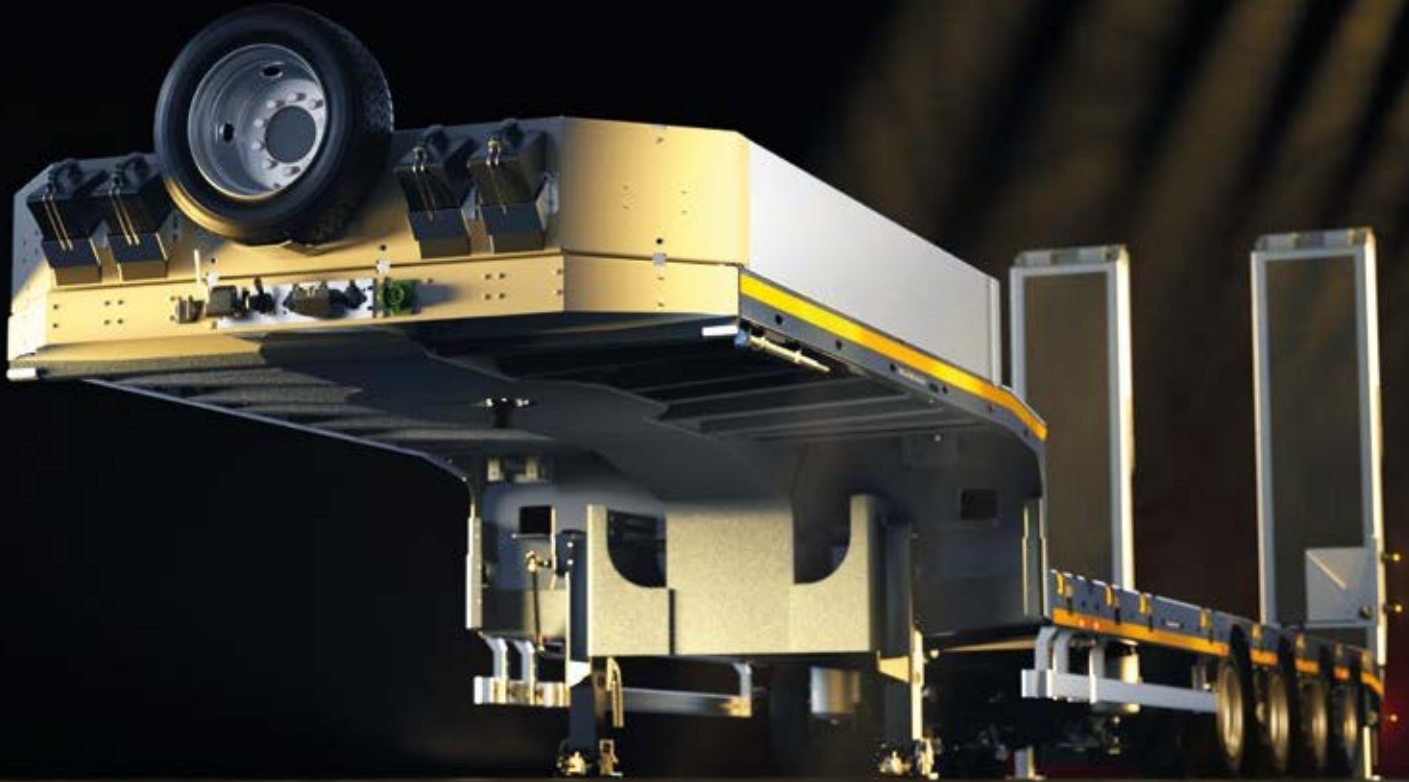

THE NEW GOLD STANDARD

SEMI LOWLOADER



MADE FOR YOUR MISSION

»STEPSTAR« IN ACTION



THE NEW GOLD STANDARD

STEP/STAR

- € **WORTH ITS WEIGHT IN GOLD.**
PREMIUM QUALITY AT
ATTRACTIVE PRICING.
- 🕒 **SIMPLY INTELLIGENT.**
FLEXIBLE VEHICLES WITH
SMART DETAILS.
- 🛠️ **EASY DOES IT.**
SIMPLE OPERATION AND
OPTIMIZED ACCESSORIES FOR
DAY-TO-DAY OPERATIONS.

STEPSTAR

A STAR IS BORN

The new generation of self-tracking semi lowloaders combines Goldhofer's proven high standard of engineering with attractive terms plus practical details such as an intelligent load securing system. With the user-friendly self-tracking semi lowloaders in the »STEPSTAR« series, you are ideally equipped for everyday haulage operations with payloads of up to 70t.



TECHNICAL FEATURES



+ 3-5 axles



+ Optional extendability



+ Removable ramps



+ 3-4 axles
with 1-2 wheel recesses

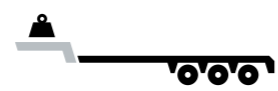

+ Standard gooseneck
18.5t/26t fifth wheel load
+ »MEGA« gooseneck
18.5t fifth wheel load



+ Folding ramps
one-piece mechanical
one-piece hydraulic
two-piece hydraulic



+ Optional excavator recess



+ 8.24 t axle load
Tires: 205/65 R 17.5
Ride height: 780 mm (-60/+140)

+ 10t/12 t axle load
Tires: 245/70 R 17.5
Ride height: 855 mm (-60/+140)

EFFICIENTLY THROUGH DENMARK WITH 36.6t PAYLOAD THANKS TO PERMANENT PERMIT

The self-tracking »STEPSTAR« semi lowloaders come with an outstanding payload-to-weight ratio. The advanced design of the »STEPSTAR« results in significant weight savings over comparable vehicles and thus an increased payload of 1 t or more. That is the key to efficient and economical utilization of your fleet.



- » 36.6t PAYLOAD WITH PERMANENT PERMIT AROUND DENMARK*
- » ECONOMIC FLEET UTILIZATION

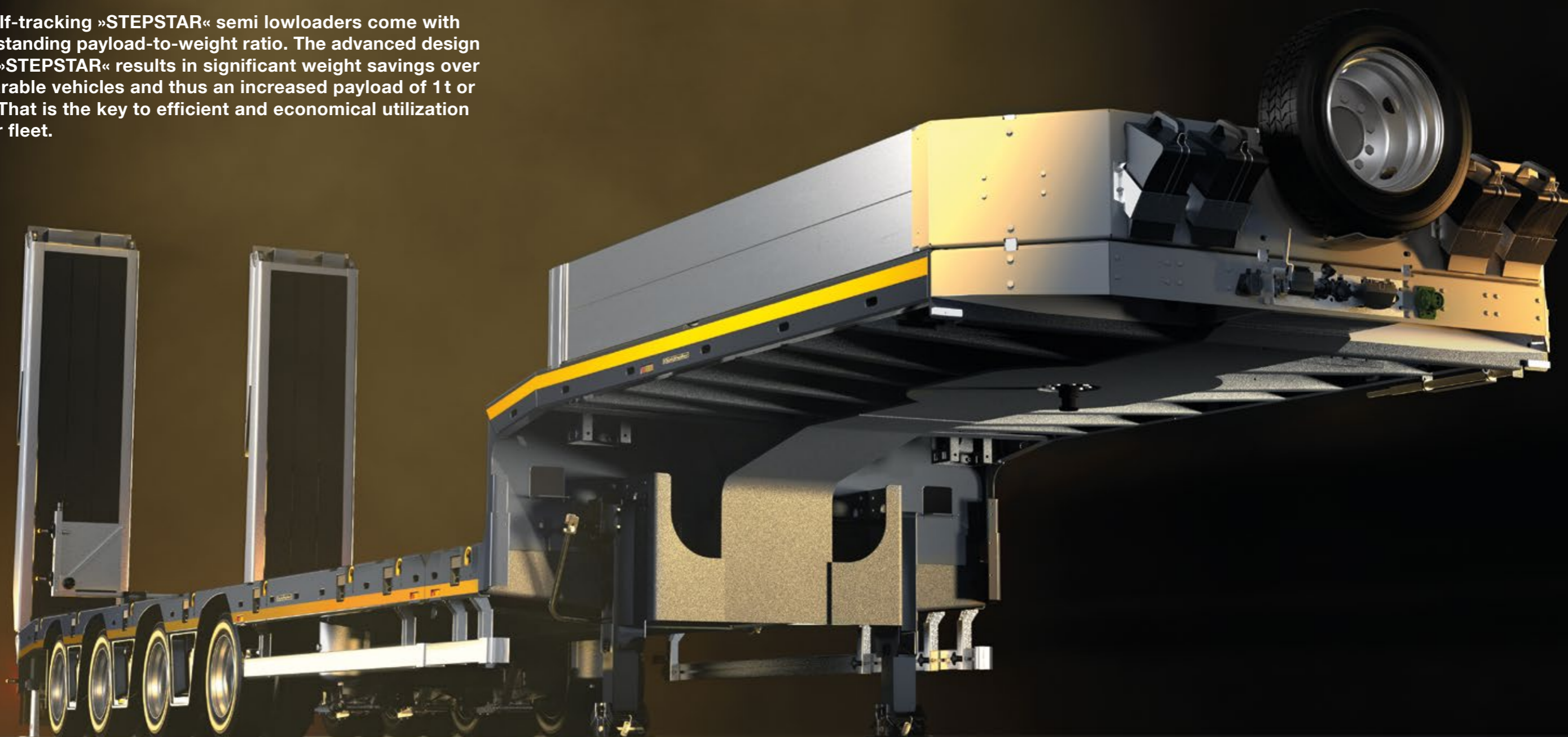

»STEPSTAR MEGA« MAXIMUM FLEXIBILITY

With the optional »MEGA« gooseneck of the »STEPSTAR« semi-trailers more loads than ever can be transported with one trailer.

The combination of the very low coupling height of a lowliner tractor with the flat construction of the »MEGA« gooseneck results in an extremely low usable loading height.

This allows the transportation of wheeled vehicles, divided loads, small parts and even a 40-foot or two 20-foot container within 16.5 m total length. The "MEGA" gooseneck is available for all vehicles of the »STEPSTAR« family.



- » SIMPLIFIED OBTAINMENT OF PERMITS
- » GREATER FLEXIBILITY – ONE VEHICLE FOR MANY TASKS



EXCELS IN TERMS OF ECONOMICS

PREMIUM COMPONENTS FOR MAXIMUM SERVICE LIFE

The use of premium components as a standard gives the »STEPSTAR« semi lowloaders their long service life. The high degree of standardization means that spare parts can be obtained quickly and easily if required.

Ultra-modern and robust polymer wings for efficient splash protection and significant weight saving

1

High quality landing gear for easy leveling on any surface

2

Low-maintenance BPW axles offering top quality

- + Simple and fast bearing and brake replacement saves approx. 90 min. per axle
- + Best delivery of spare parts for high vehicle availability

3

Robust and economical ERMAX full LED lighting system

- + Impact-resistant lighting
- + Encapsulated connecting plugs for low wear even under extreme conditions

5

Tail support legs with convenient foot or optional hydraulic operation

4



- » LIFETIME TEST UNDER THE TOUGHEST CONDITIONS
- » CONFIRMED GOLDHOFER PREMIUM QUALITY



- » EFFECTIVE PROCUREMENT OF SPARE PARTS
- » LOWER TOTAL COST OF OWNERSHIP (TCO)

EXCELS IN TERMS OF LOAD SECURING WITH INTELLIGENT LASHING SYSTEM

As an optional special feature, the »STEPSTAR« has positive-locking stake pockets on the gooseneck. The optional TRAFFIDECK™ GO deck covering is also available for enhanced load security and reduced lashing requirements.

1

- Wader container pockets
- + Recessed in the loading platform for ease of driving over
 - + Safe transport of containers

2

- Stake pockets
- + Simple securing of small parts or long material
 - + Fast, efficient load securing through positive-locking

3

- Entire loading area with RUD Optilash Fix 10t-lashing rings as well as anchor points in the frame and the excavator recess
- + Simple securing of small parts
 - + High load capacity

4

- Drive-over recessed lashing lugs on the tail
- + Retractable in the frame
 - + Optimum lashing angle for efficient lashing to the front

- Optional TRAFFIDECK™ GO floor covering
- + More loading height and 80% lighter compared to conventional rubber mats
 - + High friction coefficient ensures optimal load securing
 - + Sanding of the loading area ensures safety in all weather conditions



- » FAST AND RELIABLE LOAD SECURING
- » HIGH LEVEL OF SECURITY FOR DAY-TO-DAY OPERATIONS
- » IN COMPLIANCE WITH THE STRICTEST REGULATIONS

EXCELS IN TERMS OF LOADING HEIGHT ON ROUTES WITH HEIGHT RESTRICTIONS



» SIMPLIFIED OBTAINMENT OF PERMITS

» COST-EFFECTIVE TRANSPORTATION

1

max. length: 3,850 mm

3

Depth: 310 mm

2

Width: 760 mm

The special feature of the extra long and wide excavator recess of the »STEPSTAR« semi lowloaders is that it has no cross members and is open to the rear. This makes it possible to carry even bigger excavator booms while simultaneously reducing overall height. With up to three removable bulkheads, even small parts can be secured efficiently and space-saving.

EXCELS IN TERMS OF VERSATILITY ECONOMICAL AND LIGHT THANKS TO ALUMINIUM

»STEPSTAR« semi-trailers are optionally available with one or two wheel recesses. The loading platform can be converted quickly and efficiently for other loads thanks to the well thought-out wheel recess covers.

With the extendable vehicle variants in particular, loads with different wheelbases can be transported easily.



- » FULFILLMENT OF THE MOST STRINGENT HEIGHT GUIDELINES
- » REDUCED SET-UP TIMES FOR DIFFERENT LOADS

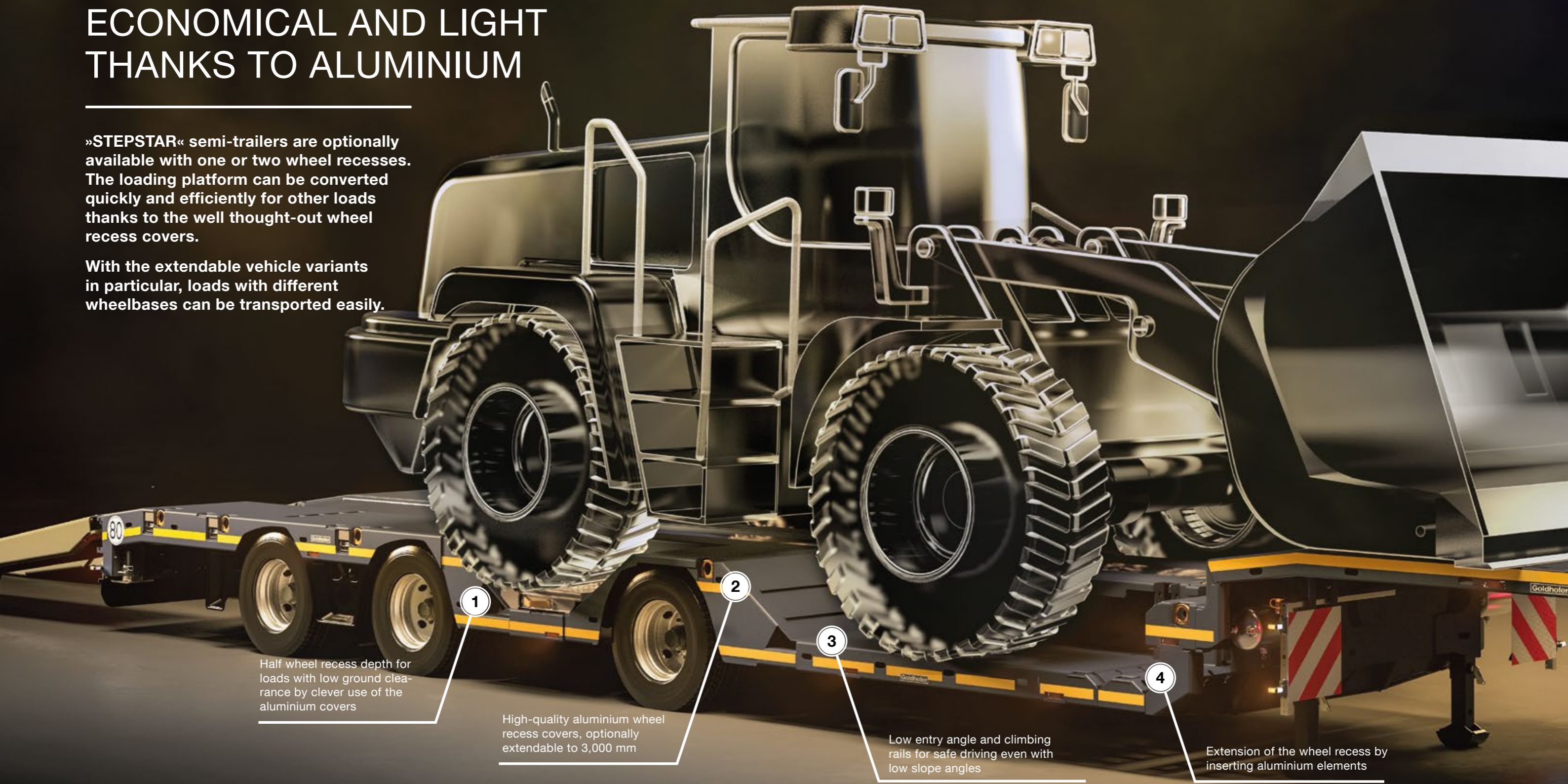

1 Half wheel recess depth for loads with low ground clearance by clever use of the aluminium covers

2 High-quality aluminium wheel recess covers, optionally extendable to 3,000 mm

3 Low entry angle and climbing rails for safe driving even with low slope angles

4 Extension of the wheel recess by inserting aluminium elements

EXCELS IN TERMS OF FLEXIBILITY

ECONOMICAL, LIGHT, AVOIDS DAMAGE TO THE GROUND

The long and light ramps of the »STEPSTAR« series are a further advantage in day-to-day transport operations. With a low ramp angle and the ground-friendly lowering mechanism, loading is child's play.

Suitable for almost all self-propelled cargos

- + Up to 3,000 mm width for safe drive-on
- + Completely shiftable for 3-wheeled vehicles

REMOVABLE RAMP

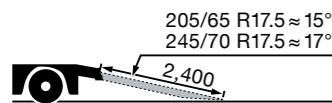

Capacity 24 t/Width 450 mm
Capacity 32 t/Width 600 mm

MECH. FOLDING RAMP (ONE-PIECE)

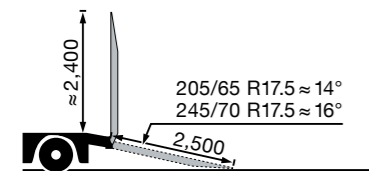

Capacity 24 t/Width 450 mm
Capacity 32 t/Width 600 mm

HYDR. FOLDING RAMP (ONE-PIECE)

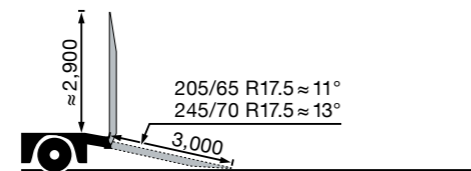

Capacity 38 t/Width 800 mm
Capacity 52 t/Width 800 mm

HYDR. FOLDING RAMP (TWO-PIECE)

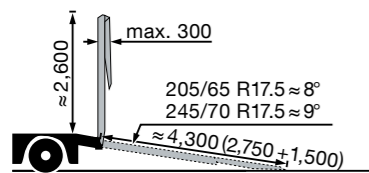

Capacity 38 t/Width 800 mm
Capacity 52 t/Width 800 mm

HYDR. FOLDING RAMP (TWO-PIECE)

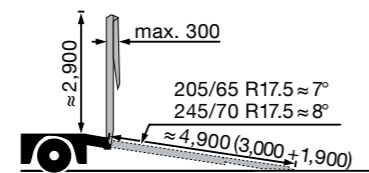

Capacity 38 t/Width 1,000 mm

3

Retrofitting for all ramps

- + Staged investment
- + Flexible approach to the transport situation

1

2

Safe and convenient operation of the ramps

- + Optional radio remote control
- + Integrated ramp protection for time saving and safe transport
- + Attachment and removal using a forklift for increased efficiency



- » FAST AND EASY LOADING
- » EFFICIENT RETURN JOURNEY

TECHNICAL DATA



TECHNICAL DATA

Fifth wheel load	18.5 t/26 t standard gooseneck 18.5 t »MEGA« gooseneck
Swing clearance radius	1,900 mm 2,100 mm 2,300 mm 2,400 mm
Vehicle width	2,550 mm
Axle spacing	1,410 mm
Max. steering angle	± 20°
Excavator recess	Max. length: 3,850 mm Width: 760 mm Depth: 310 mm
Number of axles	3-5

TIRES

	205/65 R 17.5	245/70 R 17.5
Axle load	8.24 t at 80 km/h	10 t/12 t at 80 km/h
Ride height	780 mm (-60/+140)	855 mm (-60/+140)

REMOVABLE RAMPS

Length	2,400 mm	
Capacity	24 t	32 t
Width	450 mm	600 mm
Ramp angle		
205/65 R 17.5	≈ 15°	
245/70 R 17.5	≈ 17°	

FOLDING RAMPS

	one-piece		one-piece		two-piece		two-piece	
Lifting Unit	mechanical	hydraulic	hydraulic	hydraulic	hydraulic	hydraulic	hydraulic	hydraulic
Length	2,500 mm	3,000 mm	4,300 mm	4,900 mm				
Capacity	24 t	32 t	38 t	52 t	38 t	52 t	38 t	
Width	450 mm	600 mm	800 mm	800 mm	800 mm	800 mm	1,000 mm	
Ramp angle								
205/65 R 17.5	≈ 14°	≈ 11°	≈ 8°	≈ 7°				
245/70 R 17.5	≈ 16°	≈ 13°	≈ 9°	≈ 8°				

ACCESSORIES AND OPTIONS



The self-steering semi-trailers of the »STEPSTAR« series convince with an extensive portfolio of accessories and options.

- + Pocket stakes on the gooseneck
- + Electric cable winch
- + Aluminium loading ramp
- + Optional side and end board combinations for the neck
- + Compensating chocks for gooseneck chamfer
- + Country-specific system interfaces for pneumatics and electronics

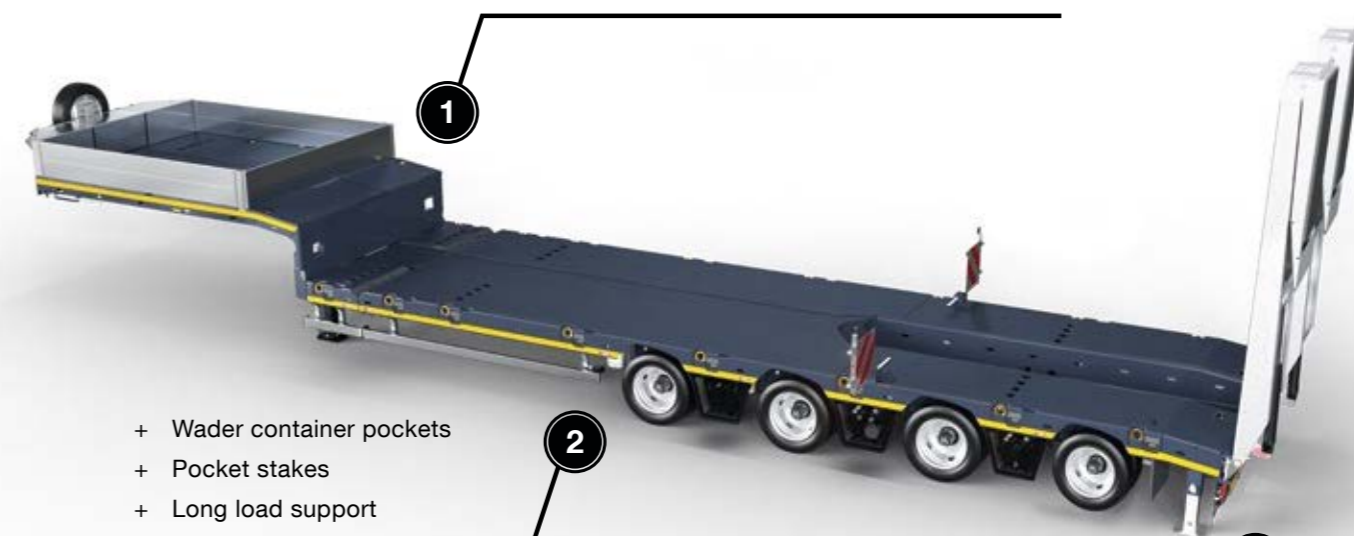

- + Wader container pockets
- + Pocket stakes
- + Long load support
- + Aluminium cover for excavator boom recess
- + Hook-in wheel recesses and bridging rails
- + Load table

- + Rear climbing pads
- + LED rear light
- + Radio remote control
- + "Convoi Exceptionnel" warning sign
- + Warning package (including several items)

STEP/STAR

TRANSPORT TECHNOLOGY

GOLDHOFER AKTIENGESELLSCHAFT

Donaustrasse 95, 87700 Memmingen/Germany
Telephone: +49 8331 15-0, Fax: +49 8331 15-239
Web: stepstar.goldhofer.com, E-Mail: stepstar@goldhofer.com

SALES

Telephone Sales Europe: +49 8331 15-341
E-Mail: stepstar@goldhofer.com

SERVICES AND SPARE PARTS

Telephone: +49 8331 15-400, Fax: +49 8331 15-247
Emergency Hotline: +49 172 837 61 65
E-Mail: service-stepstar@goldhofer.com